

## Assembly and Installation Instructions Grease Arrestor SC 2000 & 3000

2,000L

3,000L

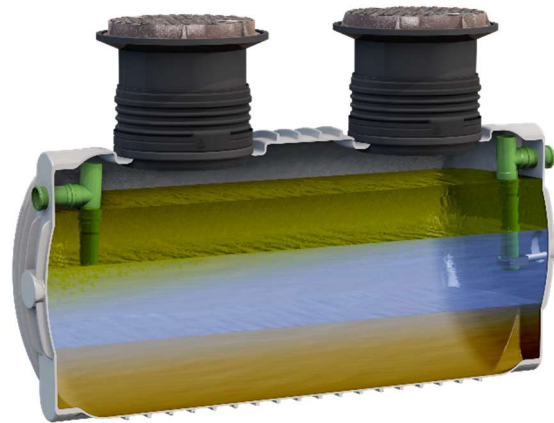

It is imperative to observe the items described in these instructions. In case of non-compliance, all warranty claims shall lapse. For all add-on items from GRAF, you shall receive separate installation instructions included with the transport packaging.

It is imperative to check the components for potential damage prior to transferring them into the building pit. The items described in these instructions apply to the separator as well as to a potential additional upstream sludge trap. For the operation and maintenance of the system, you shall receive separate instructions.

### Table of Contents

<b>1. Safety notices</b>	<b>2</b>
<b>2. Installation conditions</b>	<b>3</b>
<b>3. Assembly and Installation</b>	<b>10</b>
<b>4. Technical data</b>	<b>16</b>

## 1. Safety notices

### 1. Safety notices

The applicable accident prevention regulations in accordance with the Employers' Liability Association regulations (BGV) C22 must be observed during all work. Particularly during the walk through of the tank, a second person should be present for safety reasons.

Furthermore, all relevant regulations and standards must be observed during assembly, installation, maintenance and repair. Details hereto can be found in the respective paragraphs of these instructions.



The tank cover must remain closed at all times, except for work inside the tank, otherwise there is an increased risk of accident.



The rain protection mounted at delivery only serves as packaging for the transport and is not accessible or childproof. It must be removed immediately upon delivery and replaced by an appropriate cover (telescopic dome shaft with respective cover). Only original GRAF covers or covers approved in writing by GRAF must be used.

GRAF offers a wide range of accessory parts which are precisely coordinated and can be used to complete systems. The use of different accessory parts can lead to impact the functionality of the system, and to void liability for consequential damages.

## 2. Installation Conditions

### 2. Installation conditions

#### 2.1. Installation basics

- Existing drainpipes should be checked for matching connection heights.
- The materials of the inlet and outlet pipes must be resistant to wastewater containing grease.
- The required pipe diameter, depending on the nominal size of the separator and the required slope of the line according to the corresponding standards (EN 752-4, EN 12056-2, EN 1825-1 or equivalent AS/NZS 3500.1 and AS/NZS 3500.2), must be adhered to. Safety against buoyancy and flotation must be ensured.
- The installation instructions for the tank must be followed.
- A sampling option has to be provided. See 2.2.1.
- Proper ventilation of the inlet and outlet pipes. See 2.3.
- The condition of all components must be checked before installation and protected from damage or dirt.
- The covers must be comply with the latest version of AS 3966. They will need to be water and gas tight.

#### 2.2. Requirements for the installation site

Please ensure that the following requirements met for your installation site. For special requirements which may apply in your region please see 2.2.1

- The installation site must be frost-protected.
- The installation site should be as close as possible to the wastewater accumulation location.
- The accessibility of the inlet and outlet area for cleaning vehicles and for inspection must be ensured (alignment of the shaft structures).
- The excavation base must be installed horizontally and must have sufficient base course / bearing capacity.
- The inlet and outlet lines must be installed in compliance with EN 12056 and EN 1825-2 or equivalent AS/NZS 3500.1 or AS/NZS 3500.2.
- Separators are to be operated without backflow by gravity. Separators with outlets below the locally specified backflow level are to be connected to the drainage system according to EN 12050 by means of sewage lifting units.
- Before filling the building pit, and possibly before connecting the inlet and outlet line, the system including shaft structure should be checked for leaks. Procedures and results of the inspection should be documented.
- Special local requirements must be taken into account (e.g. water protection area, flood prone areas etc.).
- The building site must be coordinated with the relevant food and hygiene monitoring if necessary.

## 2. Installation Conditions

### 2.2.1. Special requirements

Water Corporation (WA): A sampling point according to HX33-10-00 has to be installed after the separator. For technical details please see drawing HX33-10-00 from Watercorporation.

Standard Plumbing and Drainage Regulation (QLD): A Disconnecter Gully Trap must be installed on the outlet pipe of the arrestor.

SA Water: A cap to be placed on top of the outlet pipe. This will prevent any greasy waste flowing to sewer in the event of an overflow of the arrestor.

Sydney Water: A sampling point as shown below is required on the outlet for each installation. A cap is also required on top of the outlet pipe.

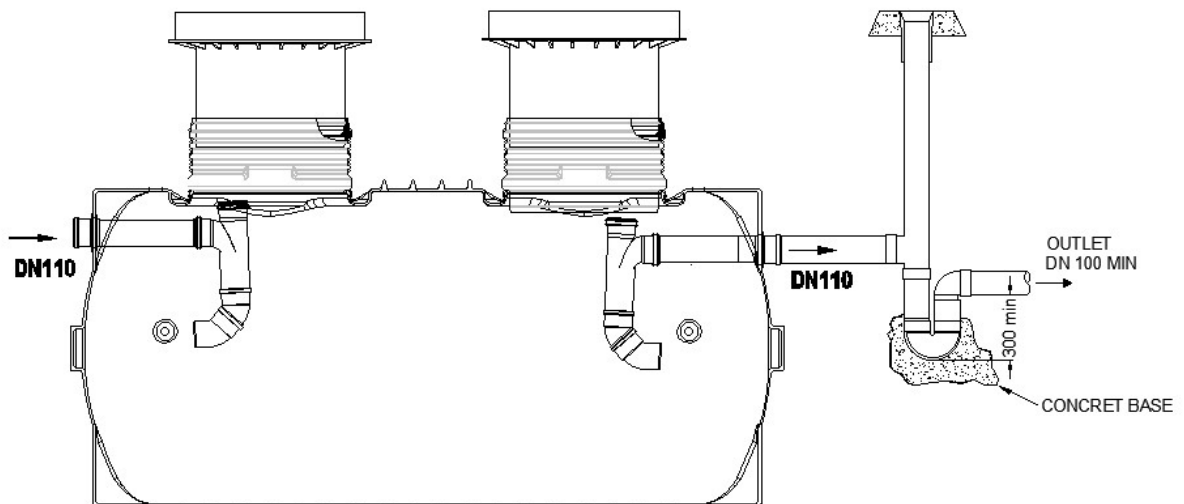

## 2. Installation Conditions

### 2.3. Venting

The separator has to be vented after the following points. For special requirements which may apply in your region please see 2.3.1

- Inlet and outlet lines on grease separators must be adequately vented.
- All plumbing and venting pipework connections need to be performed as per requirements of Water Services Licensing (Plumbers Licensing and Plumbing Standards) Regulations 2000 (WA only) and the latest versions of AS/NZS 3500.1 an AS/NZS 3500.2. A draught intensifier supports the ventilation.

#### 2.3.1. Special requirements

Water Corporation (WA) and QLD Standard Plumbing Regulation: A venting pipework with DN 100 has to be installed according to HX33-10-00.

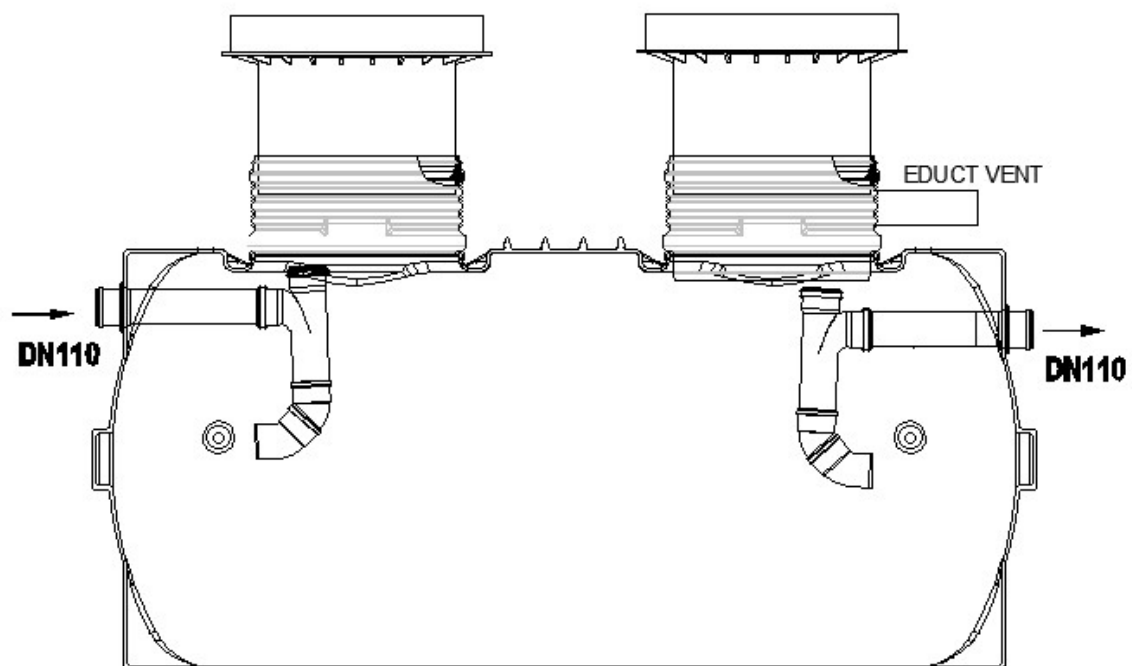

If the telescopic lid falls in front of the vent opening, please make sure to cut out the section that obstructs the venting as shows on the right.

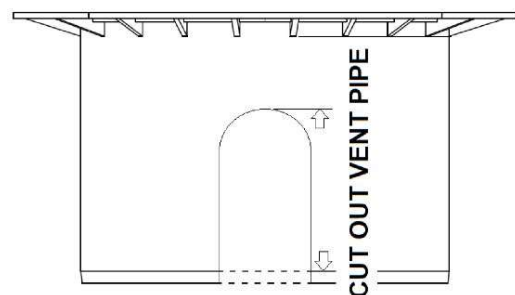

## 2. Installation Conditions

### 2.4. Building site

The tank must only be installed in non-cohesive soil to slightly cohesive soil (G1 group, condition A4 and B4, degree of compaction DPR = 97 %, according to ATV-DVWK-A 127). In case of deviating installation conditions, a separate verification must be carried out. The following issues must be clarified prior to installation:

- The structural suitability of the ground.
- Maximum occurring ground water levels and infiltration capacity of the ground.

To determine the soil physical factors, a ground assessment must be carried out.

#### 2.4.1. Ground level cover

- Under pedestrian areas not subject to traffic load or high groundwater

Earth cover	2000L	3000L
EC Min	-	-
EC Max	1500 mm	1500 mm

- Under trafficable areas (class B and class D) or areas subject to high groundwater

Earth cover	2000L	3000L
EC Min	700 mm	700 mm
EC Max	1500 mm	1500 mm

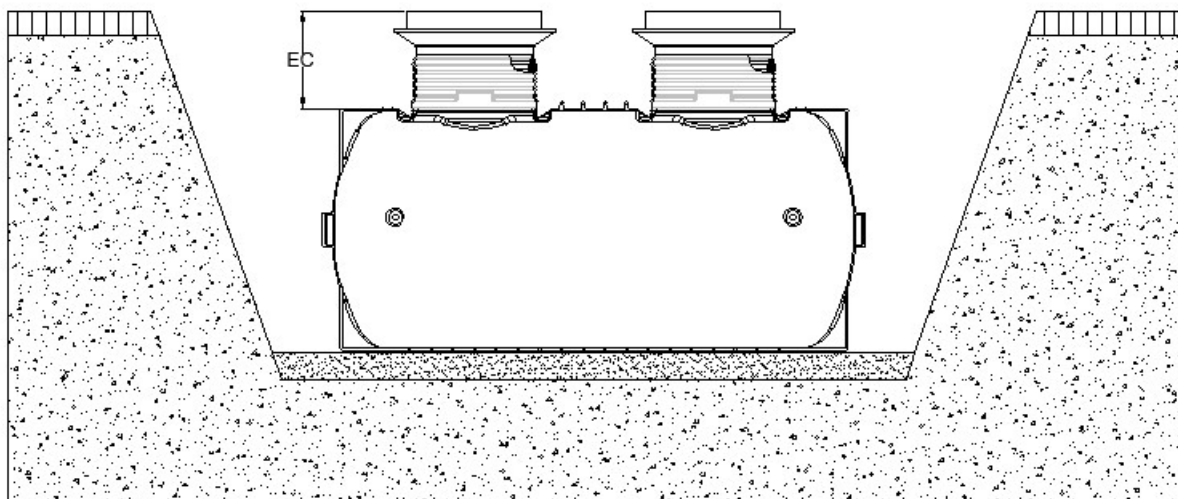

## 2. Installation Conditions

### 2.4.2. Slope, embankment, etc.

During the installation of the tank in close proximity (<5 m) to a slope, mound or embankment (greater than 5°), a statically calculated retaining wall must be built to absorb the active earth pressure. The wall must exceed the tank dimensions by at least 500 mm and must have a minimum clearance of 1000 mm from the tank.

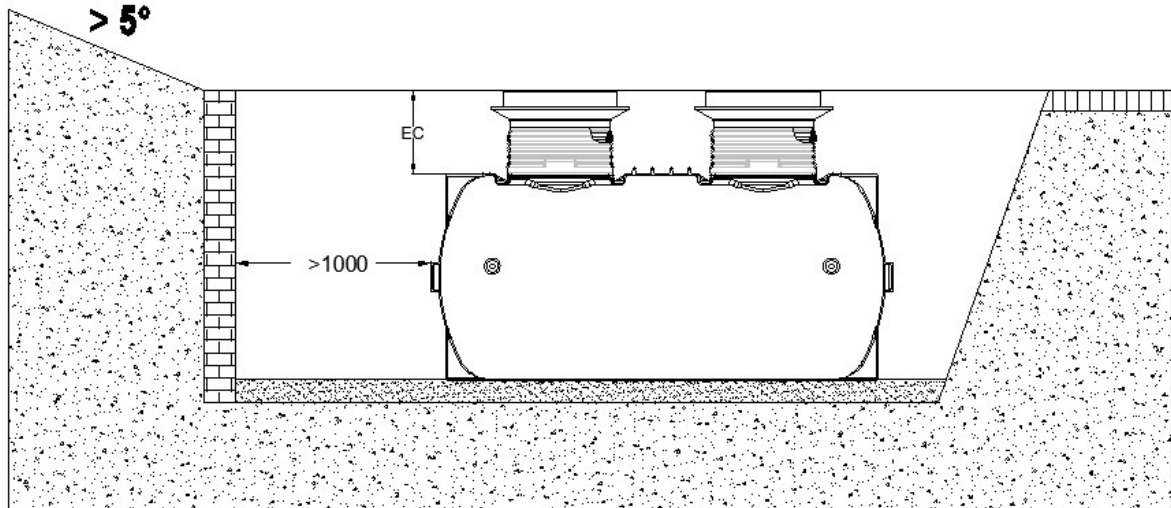

### 2.4.3. Ground water and cohesive (water-impermeable) soil (e.g. clay soil)

The tank must only be installed into groundwater/stratum water up to the levels specified in the following table. If it is to be expected that groundwater/stratum water levels - even if only occasionally - exceed these levels, it must be drained.

The drainage line may end up in a vertically installed DN 300 pipe, equipped with a submersible pressure pump that drains the excess water. The pump must be inspected in regular intervals.

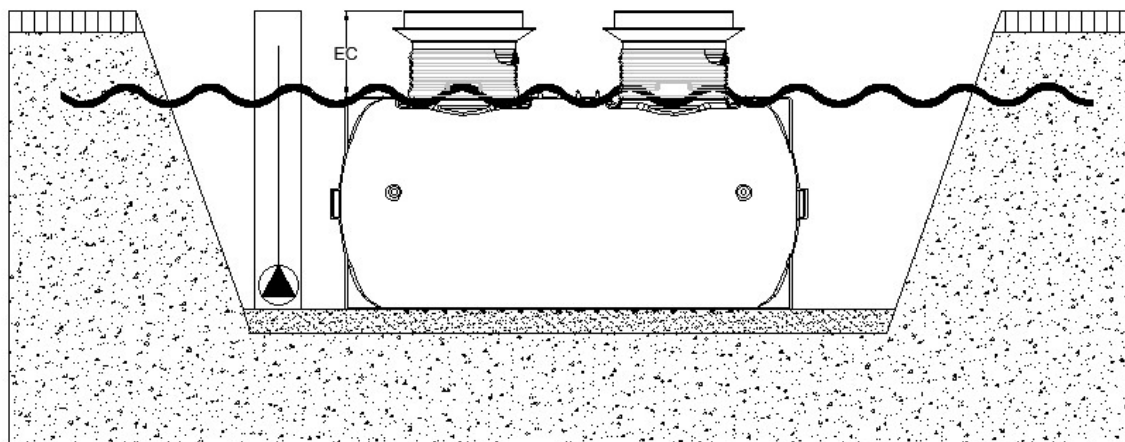

	2000L	3000L
Groundwater up to:	1100 (tank shoulder)	1350 (tank shoulder)

## 2. Installation Conditions

### 2.4.4. Accessible cover Class A (AS 3996)

If there is no car traffic over the tank area and no load distribution plate is installed, the clearance to the passable areas must correspond with the building pit depth.

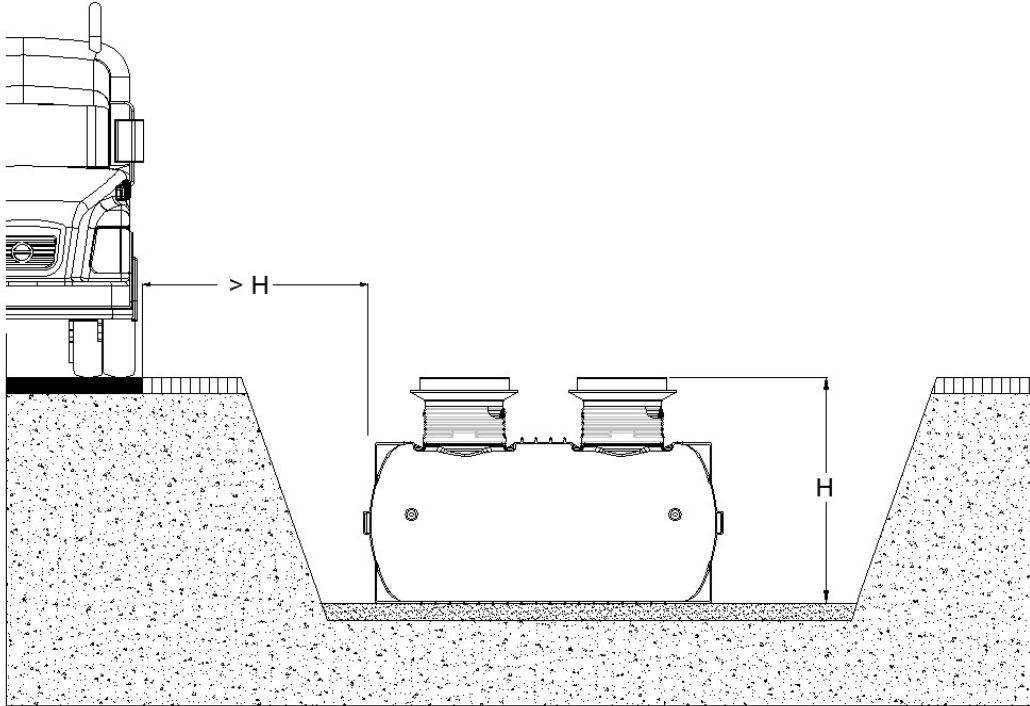

### 2.4.5. Cover suitable for car traffic Class B (AS 3996)

In case of car traffic, an appropriate cover according to AS 3996 class B must be used. In addition, the telescopes must be equipped with a concrete collar. In reference to this, please see section 3.3.2.

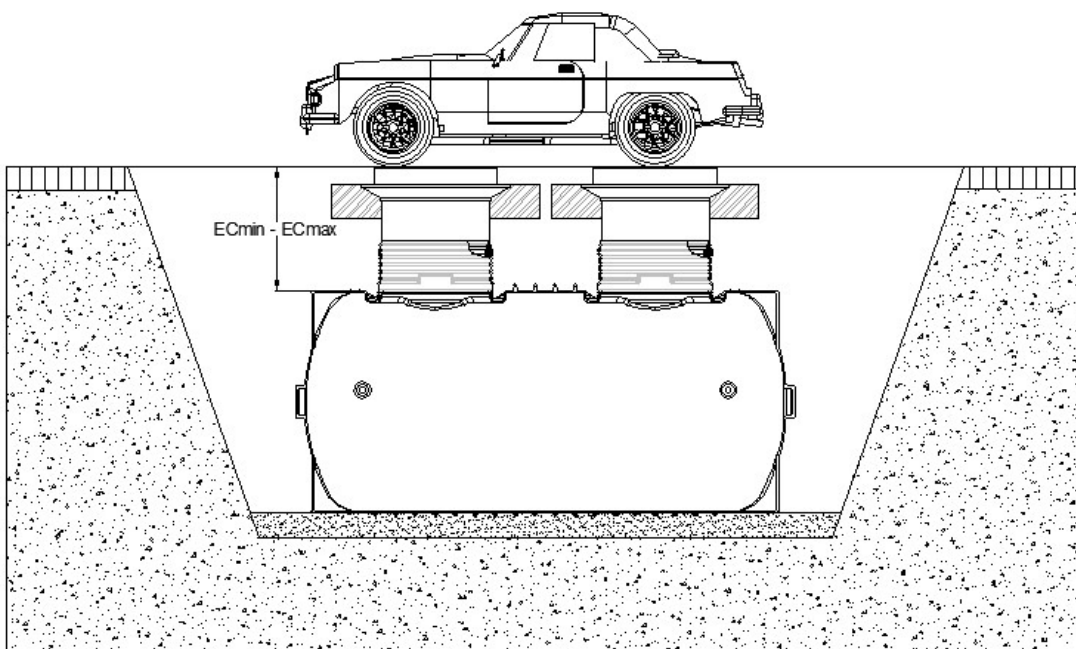



## 2. Installation Conditions

### 2.4.6. Cover suitable for truck/heavy load Class D (AS 3996)

In case of heavy truck traffic, an appropriate cover according to AS 3996 class D must be used. In addition a load distribution plate must be provided on site (structural drawing available at GRAF).

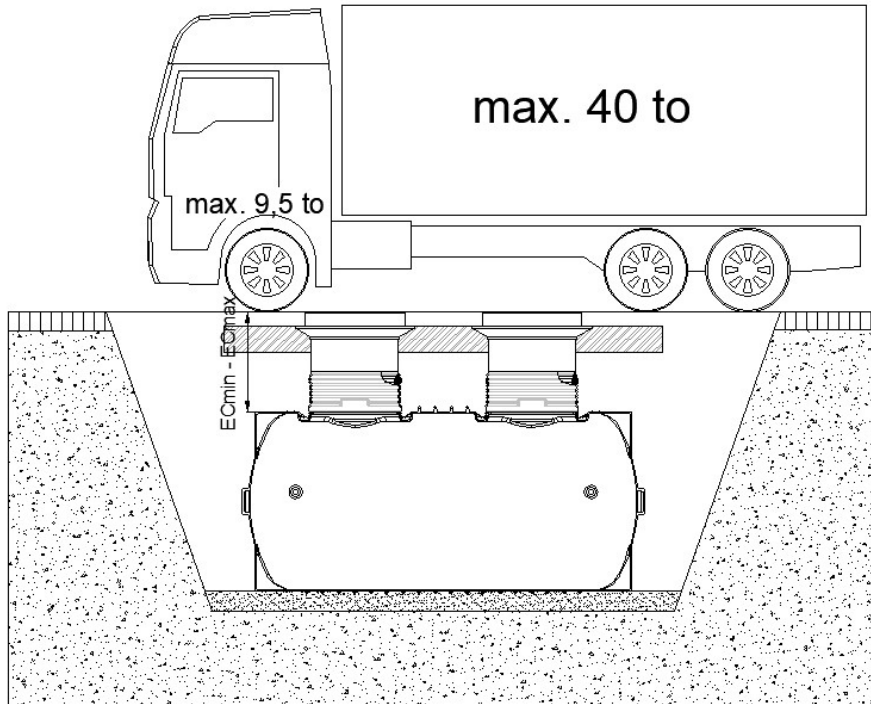

## 3. Installation conditions

### 3. Assembly and Installation

#### 3.1. Building pit

In order to leave adequate work space, the ground surface of the building pit must exceed the tank dimensions by > 500 mm on each side. The clearance to fixed structures must be at least 1000 mm.

A slope with the angle  $\beta$  must be applied according to the following table.

Soil type	Slope angle $\beta$ in °
Non-cohesive or soft, cohesive soil	$\leq 45^\circ$
➔ Tank must be suitable for car traffic (cover B125, D400)	$\leq 50^\circ$
Stiff or semi-firm, cohesive soil (tank accessible only)	$\leq 60^\circ$
Rock (tank accessible only)	$\leq 80^\circ$

Attention: In order to be suitable for car traffic, a slope angle of a maximum of  $50^\circ$  must be adhered to. The building site must be horizontal and even and must provide adequate load-bearing capacity.

The depth of the pit must be dimensioned, so that a maximum ground level cover (a maximum of 1500 mm over the tank collar) is not exceeded.

A layer of compact grounded gravel (maximum grain size 8/16 mm, thickness at least 150 mm) must be laid down as a substructure.

## 3. Installation conditions

### 3.2. Final installation

#### 3.2.1. Positioning of the tank

The tank must be placed shock-proof and with adequate equipment into the prepared building pit. After placing the tank, it must be positioned in the pit in such a way that the inlet is aligned along the axis of the inlet line. The tank should be positioned vertically. Make sure the outlet of the separator is placed 7cm deeper than the inlet. After positioning the tank, fill the pit layer by layer according to section 3.2.2.

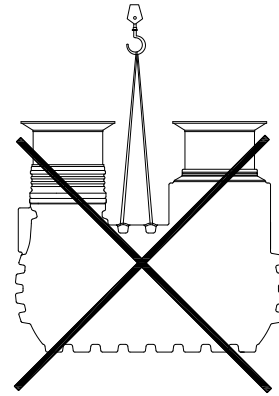

#### 3.2.2. Backfill

In order to avoid deformations of the tanks, the filling of the tank and the filling of the building pit should be carried out simultaneously. Before filling the excavation, the tank will be filled up to 1/3; then the excavation is filled with layers of a maximum of 30 cm (grounded gravels with a maximum grain size of 8/16) up to the tank's upper edge. The individual layers must be compacted well (manual compactor). In order to prevent damage to the tank, the use of mechanical compacting equipment is not permitted at any time. The excavation must be at least 500 mm wide.

Attention: In order to be suitable for truck traffic (SLW40), a geotextile must be horizontally installed around the clearance areas!

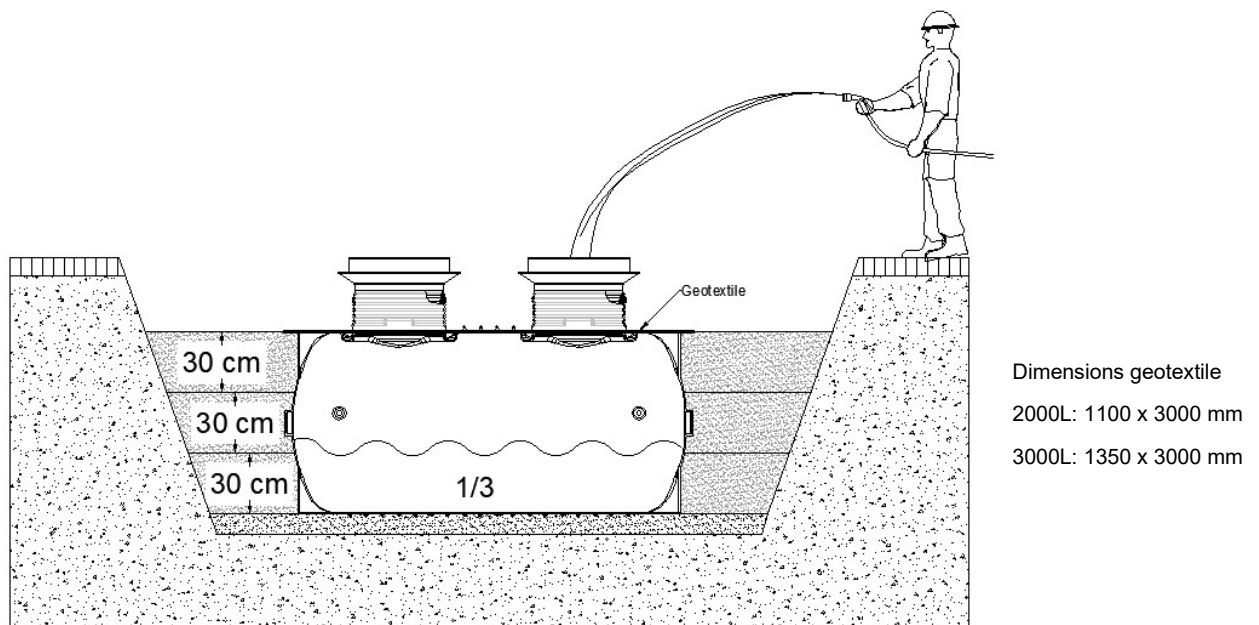

#### 3.2.3. Connection of inlet and outlet

Connect the inlet and outlet lines once the pit has been filled as far as the connections.

### 3. Installation conditions

#### 3.2.4. Positioning of the assembly components

After connecting the inlet and outlet lines, check whether the assembly components are in a vertical position. If they are not, position them according to the following figure. Push the inlet pipe towards the wall of the tank until the spacer touches the wall. The outlet pipe must be pushed as far in the direction of the wall, until the complete pipe cross section is still visible from above on the installed structure.

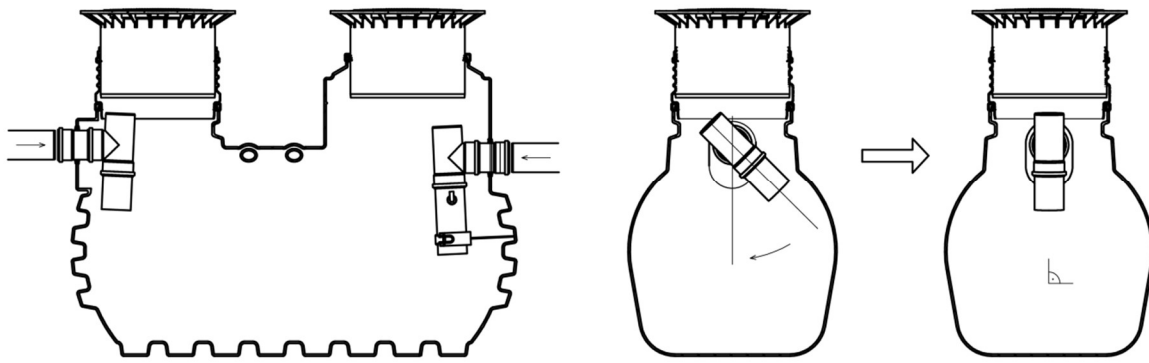

Positioning the pipe axis

Position the inlet and outlet constructions vertically

### 3. Installation conditions

#### 3.2.5. Installation of adaptors and the telescopic dome shaft

The profile gasket (6) must be mounted onto the tank (7) opening and the tank dome (5) inserted as far as the stop. Before inserting the tank dome, the seal must be lubricated with soft soap. The seal (4) is mounted into the tank dome and the telescopic dome shaft (3) is inserted

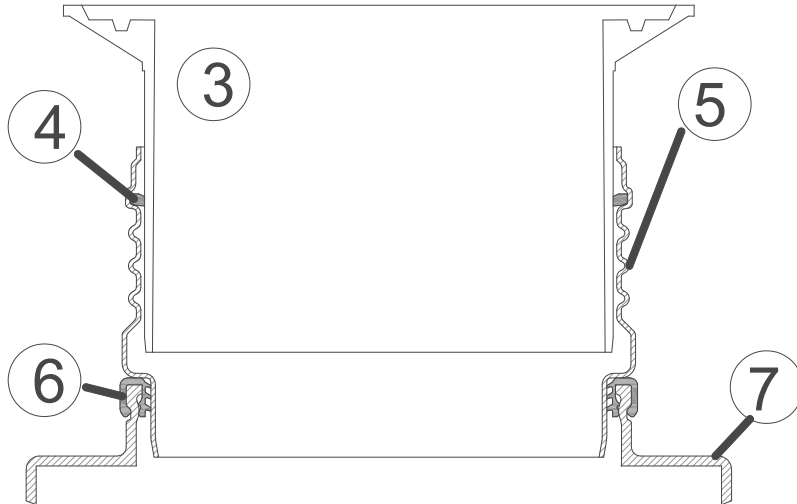

#### 3.2.6. Installation of telescopic dome shaft directly onto the tank

In order to install the telescopic dome shaft onto the tank, the profile gasket (6) is mounted onto the tank opening and the telescopic dome shaft is inserted.

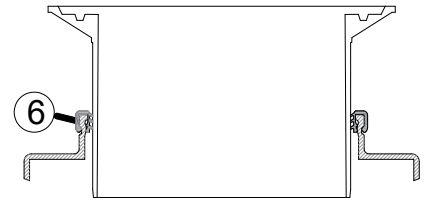

### 3.3. Installation of the shaft structures

**Instructions regarding the covers:** The covers used for grease separators must meet the provisions of the latest version of AS 3996. The cover(s) must not be equipped with openings to vent.

The lids shall need to be operated by common (Gatic type) lid lifters (see images below).



### 3. Installation conditions

#### 3.3.1. Accessible

In order to prevent transferring loads onto the tank, the telescope is filled with layers of grounded gravels (maximum grain size 8/16) and compacted evenly. Afterwards, a tubular seal ② is inserted into the groove of the telescopic dome shaft for trucks ③. Finally, the cast iron cover ① is placed onto the telescopic dome shaft.

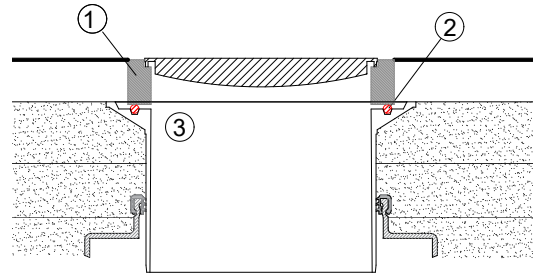

#### 3.3.2. Suitable car traffic (cover B125)

If the tank is installed underneath an area with car traffic, concrete underlay (property class C25/30) must be placed in the collar area under the telescopic dome shaft for trucks ③. The circumference of the concrete layer to be filled in must be at least 300 mm wide and approx. 200 mm high. Afterwards, a tubular seal ② is inserted into the groove of the telescopic dome shaft for trucks ③. At last, the cast iron cover ① is placed onto the telescopic dome shaft.

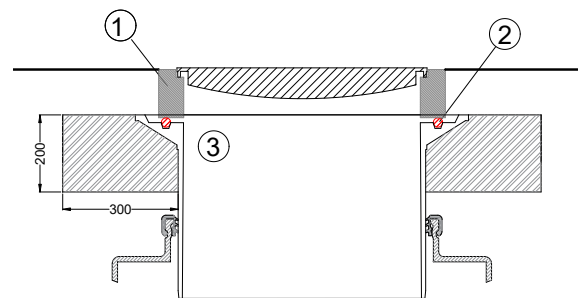

The attachment parts may only bear load after the installation is complete (concrete is cured).

#### 3.3.3. Suitable for heavy load traffic (SLW40, cover D400)

A load distribution plate (property class C40/50) must be installed under the telescope for installations in areas with heavy load traffic. A respective formwork and reinforcement plan is available from the manufacturer. An adequately compacted, anti-capillary and draining base course must be installed underneath the load distribution plate. A geotextile must be laid horizontally at the level of the tank opening. Afterwards, a tubular seal ② is inserted into the groove of the telescopic dome shaft for trucks ③. At last, the cast iron cover ① is placed onto the telescopic dome shaft.

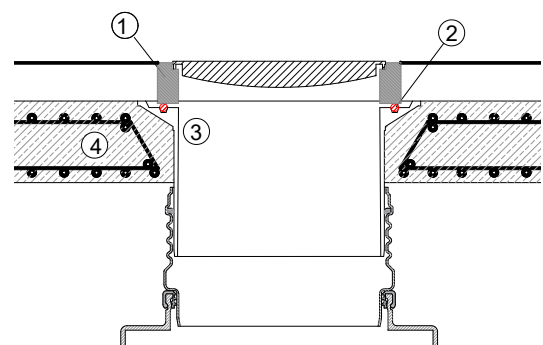

### 3. Installation conditions

#### 3.4. Commissioning

- Each grease separator is delivered with an identification plate pre-installed on the last riser closest to the finished cover level. If there isn't one in place already, please contact GRAF Australia immediately.



- To commission the separator, fill it with grease-free and oil-free water until the water begins to flow out of the discharge pipe. If a mixture of oil and water is fed into an empty tank, the separator system will not work properly and the wastewater would leave the separator system insufficiently treated.
- All relevant information, including the serial number from the identification plate must be entered into this operating manual!
- Commissioning must be documented in the commissioning report. Any claims under the warranty can only be made if the completed commissioning report is provided!

## 4. Technical data

### 4.1. 2000L tank series

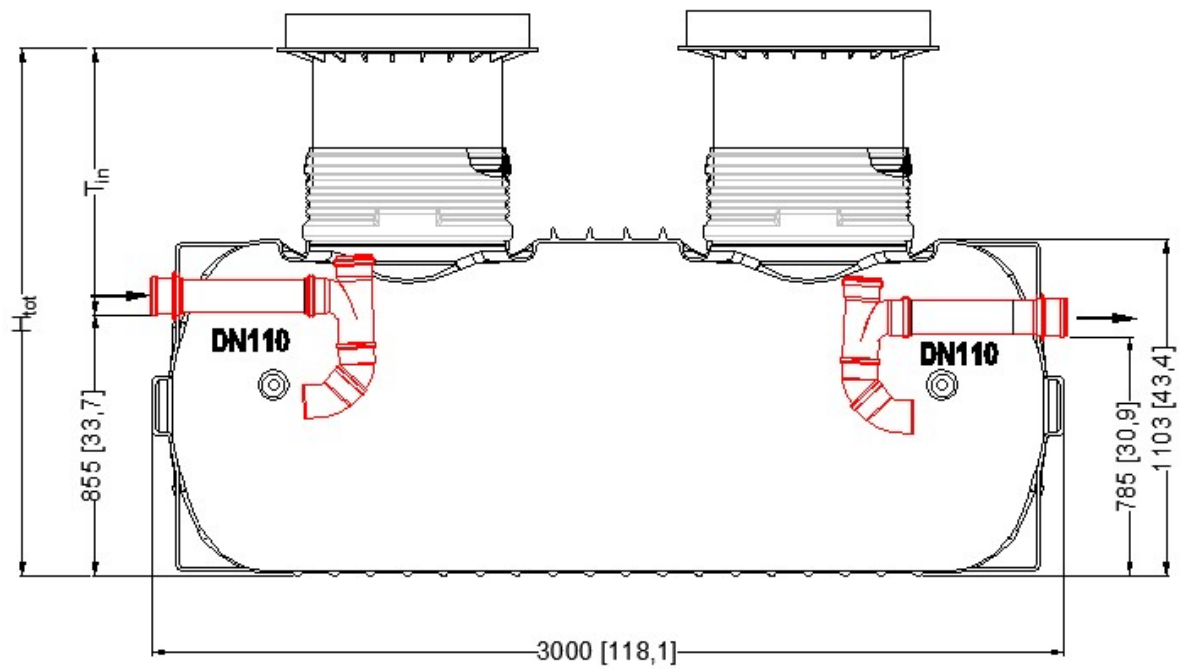

GGA-SC		2000L
Heights	$T_{in}$ [mm]	620 - 920
	$H_{tot}$ [mm]	1475 - 1775
Connections	DN	100
Weight	[kg]	193



## 4. Technical Data

### 4.2. 3000L tank series

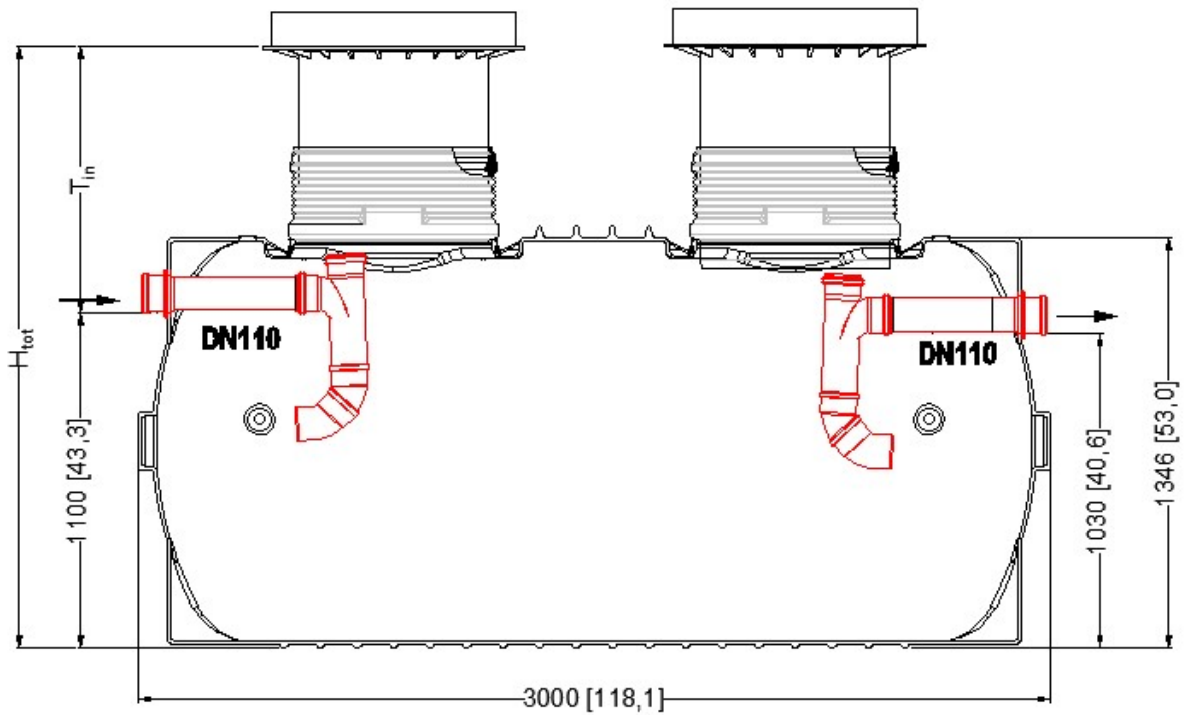

GGA-SC		3000L
Heights	$T_{in}$ [mm]	615 - 915
	$H_{tot}$ [mm]	1715 - 2015
Connections	DN	100
Weight	[kg]	240

