

- Legend Air Line Conduits / Electrical power**
- A Aeration 19mm Hose required (blue)
  - C Charging Lifter 19mm Hose required (red)
  - D Discharging Lifter 19mm Hose required (black)
  - S Sludge Return 19mm Hose required (white)
  - LS H/L Float Switch
  - P Pump

<b>D</b>		<b>GRAF EPro Commercial 7200 L/d (40EP) 4x Carat S 6500 L, 1x Carat S 2700 L</b>		Artikel-Nr. product no. article no. articulo no.	<b>20.1006</b>
TOP VIEW Wastewater Treatment, Compressed air and SECTION C-C				revision	
gezeichnet drawn		Gewicht weight		GRAF Australia Pty Ltd 23 Success Way Henderson WA 6166 Phone: +61 8 9437 4949 Email: info@grafplasticsaustralia.com.au Web: www.grafplasticsaustralia.com.au	
Datum date	2017.02.10	Toleranz tolerance	+/- 3%		
Maßstab scale	M 1:50	Einheiten units	mm [inch] gal. = US gal.		

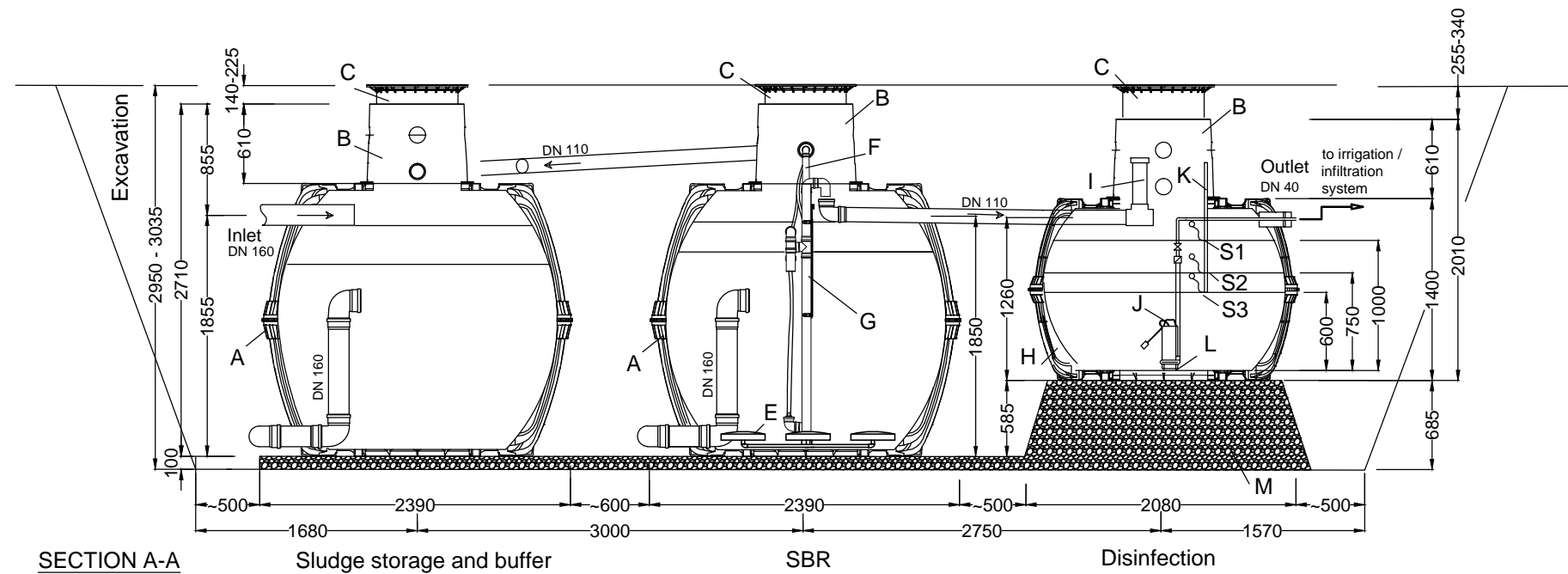



- A Carat Tank 6500L
- B Tank Dom Maxi
- C Tele Lid Mini
- D Charging Lifter
- E Diffusor
- F Sludge Lifter
- G Discharging Lifter
- H Carat Tank 2700L
- I Tablet Feeder
- J Irrigation Pump
- K Float (S1, S2, S3)
- L Pump Platform
- M Compacted Base Material
- N Internal Alarm Plate (optional)
- O Control Cabinet Metal
- P Cabinet Ventilation Fan
- Q Approved Backfill

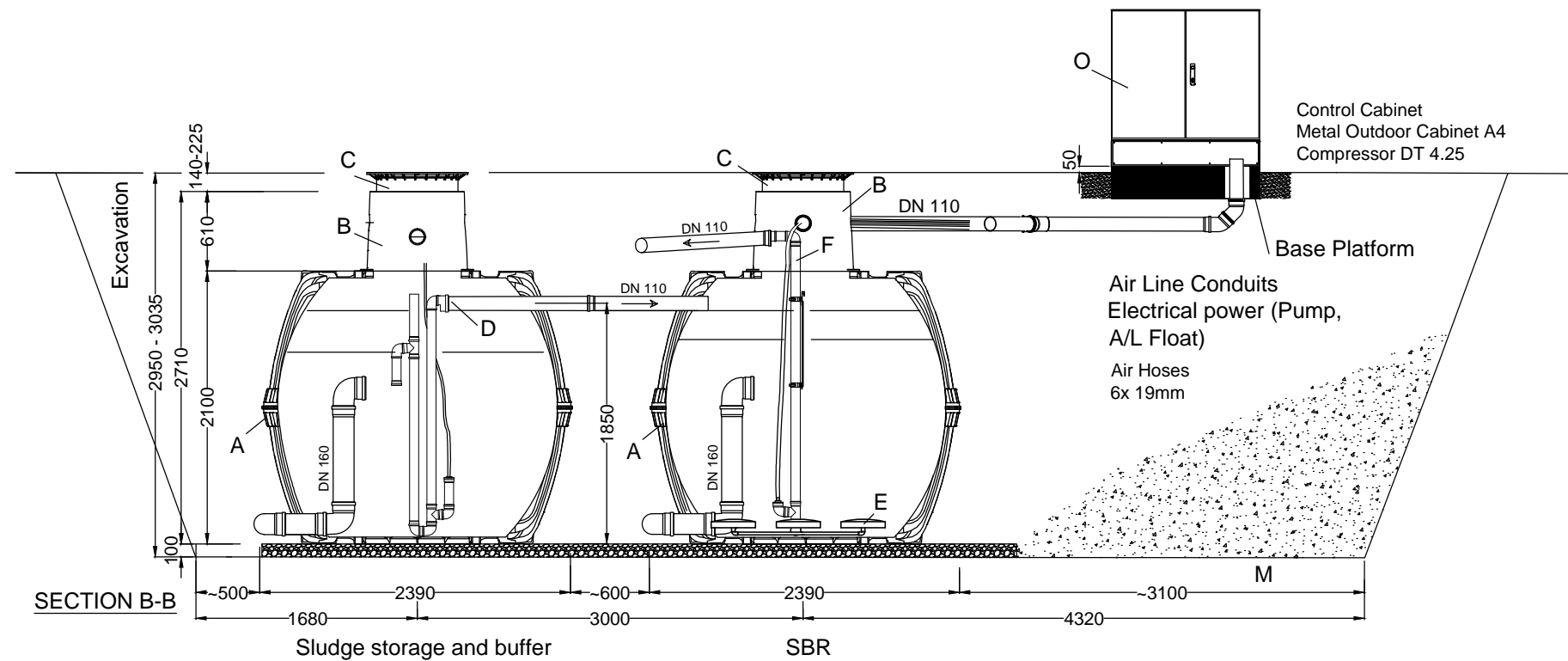

<b>D</b>		<b>GRAF EPro Commercial 7200 L/d (40EP)</b> 4x Carat S 6500 L, 1x Carat S 2700 L	Artikel-Nr. product no. article no. articulo no.	<b>20.1006</b>
SECTION A-A and SECTION B-B			revision	
gezeichnet drawn	Gewicht weight	GRAF Australia Pty Ltd 23 Success Way Henderson WA 6166		
Datum date	2017.02.10	Toleranz tolerance	+/- 3%	
Maßstab scale	M 1:50	Einheiten units	mm [inch] gal. = US gal.	
		Phone: +61 8 9437 4949 Email: info@grafplasticsaustralia.com.au Web: www.grafplasticsaustralia.com.au		